

The information in this document is subject to change without notice and should not be construed as a commitment by ABB. ABB assumes no responsibility for any errors that may appear in this document.

Except as may be expressly stated anywhere in this document, nothing herein shall be construed as any kind of guarantee or warranty by ABB for losses, damages to persons or property, fitness for a specific purpose or the like.

In no event shall ABB be liable for incidental or consequential damages arising from use of this document.

This document and parts thereof must not be reproduced or copied without ABB's written permission, and contents thereof must not be imparted to a third party nor be used for any unauthorized purpose. Contravention will be prosecuted.

Additional copies of this document may be obtained from ABB at its then current charge.

© Copyright 2023 ABB ALL right reserved.

ABB

SE-721 68 Västerås
Sweden

Latest revision: ECO 131728, WI 499329 Page 7/1: A43.X11 was A43.X12. Page 9.b/2-5: Varistor "X11 to X15" adjusted & JMP (5x) added.	
Prepared by, date: EM, 2024-02-13	Approved by, date: SH, 2024-02-22



Lab/Office:
RMRO SE/RDP

SERVICE DIAGRAM POS IF B/D.D2009
COPYRIGHT PAGE

Status: APPROVED	Plant: = Location: + Sublocation: +
Document no. 3HAC035754-005	Rev. Ind 04
	Page 1 Next 2 Total 16

We reserve all rights in this document and in the information contained therein. Reproduction, use or disclosure to third parties without express authority is strictly forbidden. © Copyright 2003 ABB

We reserve all rights in this document and in the information contained therein. Reproduction, use or disclosure to third parties without express authority is strictly forbidden. © Copyright 2003 ABB

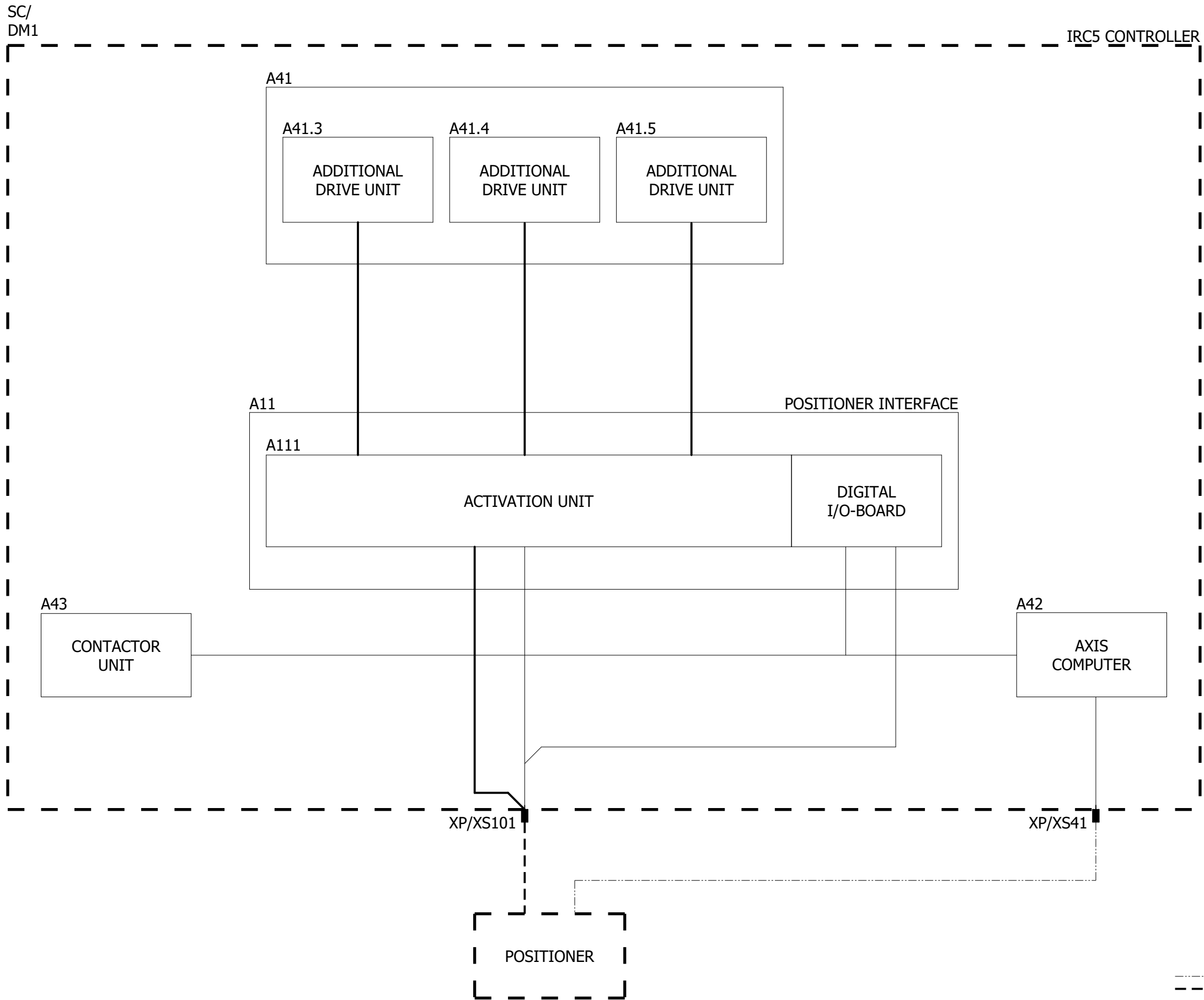

--- CONNECTION NOT INCLUDED IN CIRCUIT DIAGRAM

Latest revision:
 ECO 131728, WI 499329
 Page 7/1: A43.X11 was A43.X12.
 Page 9.b/2-5: Varistor "X11 to X15" adjusted & JMP (5x) added.
 Prepared by, date: EM, 2024-02-13 | Approved by, date: SH, 2024-02-22



Lab/Office:
RMRO SE/RDP

SERVICE DIAGRAM POS IF B/D.D2009
 BLOCK DIAGRAM
 BEFORE RELEASE 14.1

Status:
APPROVED

Plant: =
 Location: +
 Sublocation: +

Document no. 3HAC035754-005
 Rev. Ind 04
 Page 4.a
 Next 4.b
 Total 16

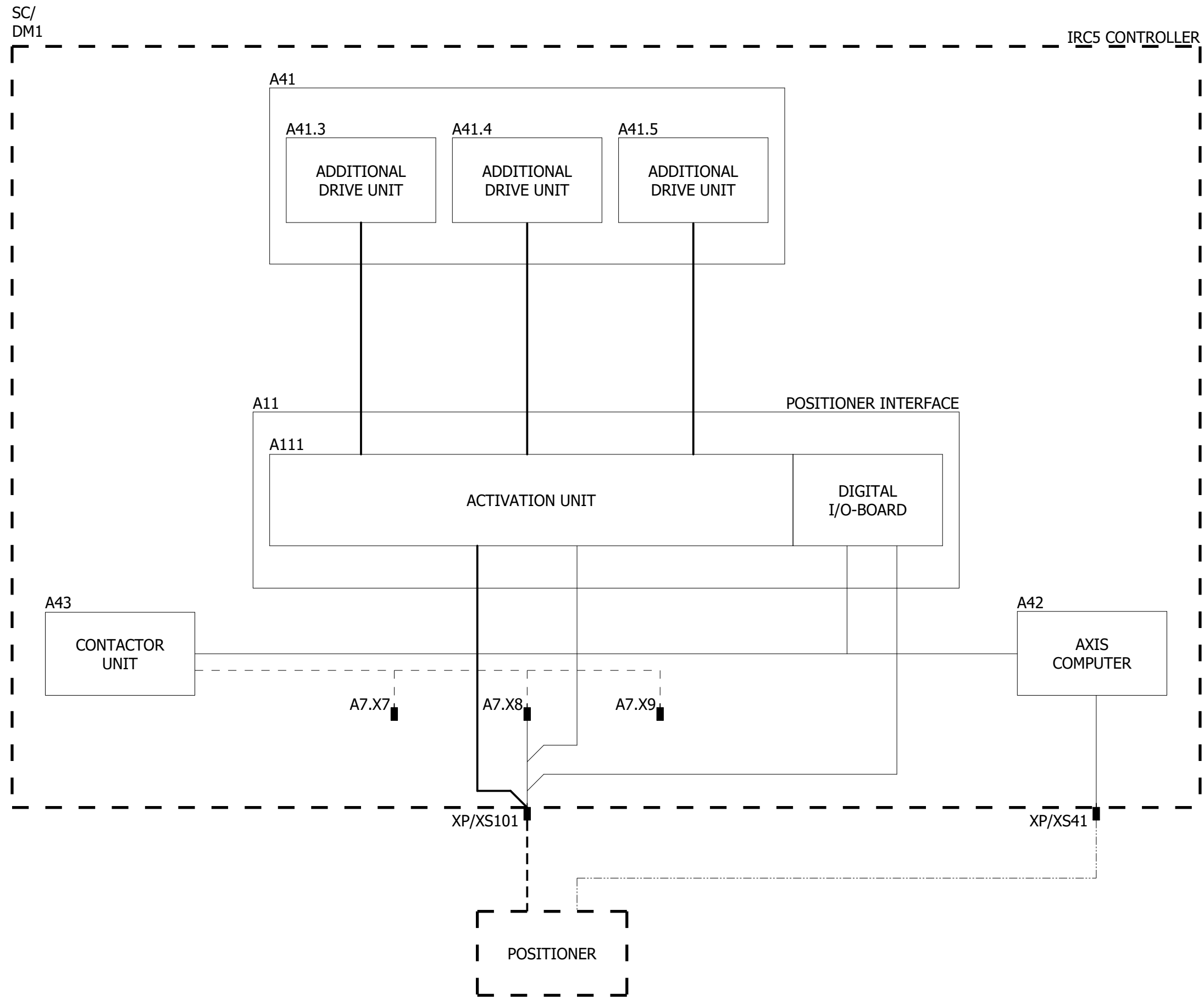

----- CONNECTION
 - - - - - NOT INCLUDED IN
 - . - . - CIRCUIT DIAGRAM

Latest revision:
 ECO 131728, WI 499329
 Page 7/1: A43.X11 was A43.X12.
 Page 9.b/2-5: Varistor "X11 to X15" adjusted & JMP (5x) added.
 Prepared by, date: EM, 2024-02-13 | Approved by, date: SH, 2024-02-22



SERVICE DIAGRAM POS IF B/D.D2009
BLOCK DIAGRAM
RELEASE 14.1

Status: **APPROVED**
 Document no. **3HAC035754-005**
 Rev. Ind **04**
 Plant: =
 Location: +
 Sublocation: +
 Page 4.b
 Next 5
 Total 16

We reserve all rights in this document and in the information contained therein. Reproduction, use or disclosure to third parties without express authority is strictly forbidden. © Copyright 2003 ABB

We reserve all rights in this document and in the information contained therein. Reproduction, use or disclosure to third parties without express authority is strictly forbidden. © Copyright 2003 ABB

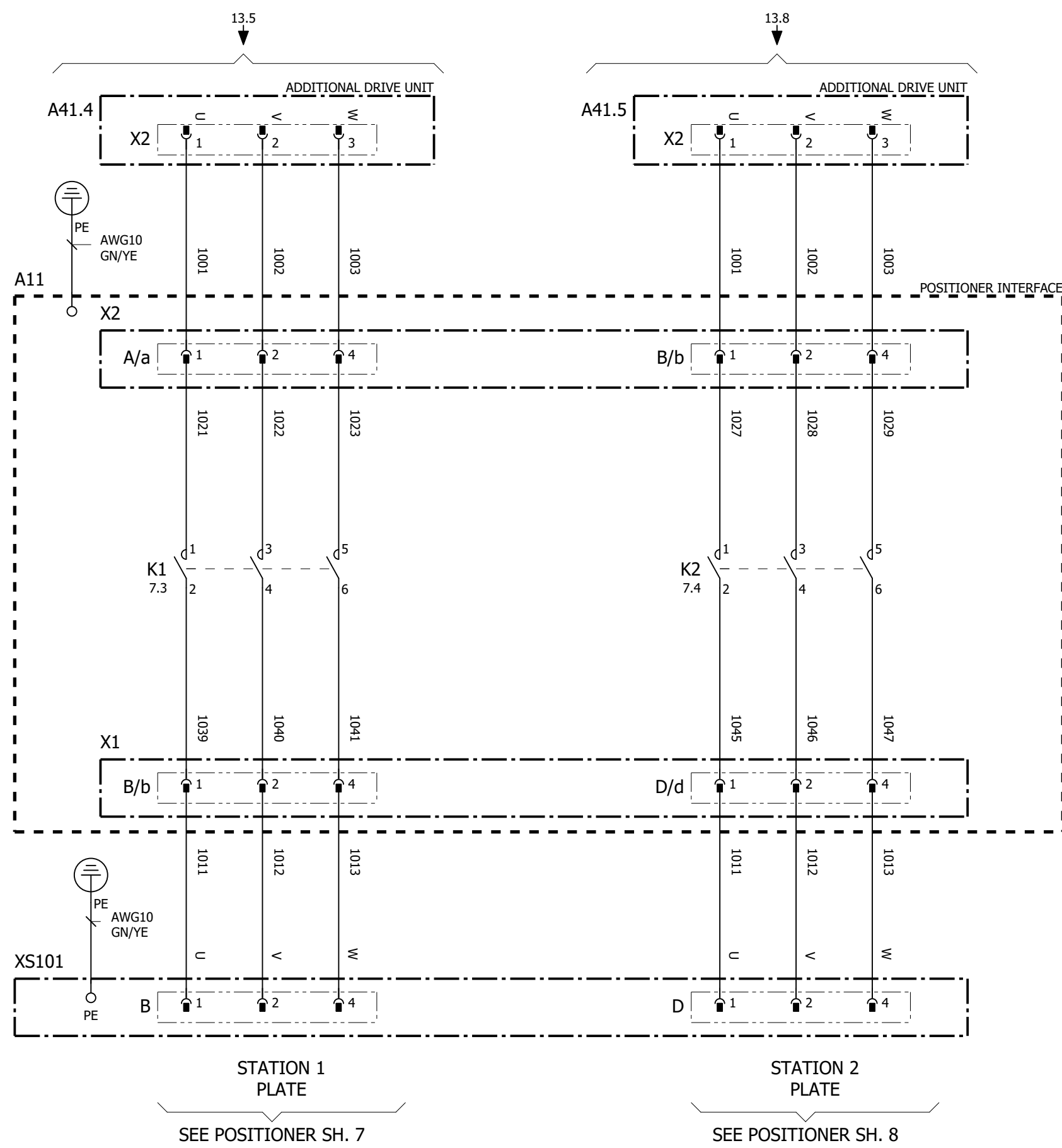

CONNECTED WITH AWG12 BK,
IF NO OTHER NOTATION

Latest revision:
ECO 131728, WI 499329
Page 7/1: A43.X11 was A43.X12.
Page 9.b/2-5: Varistor "X11 to X15" adjusted & JMP (5x) added.
Prepared by, date: EM, 2024-02-13 | Approved by, date: SH, 2024-02-22

ABB Lab/Office:
RMRO SE/RDP

**SERVICE DIAGRAM POS IF B/D.D2009
MOTORS STN 1 AND STN 2**

Status: APPROVED	Plant: = Location: + Sublocation: +
Document no. 3HAC035754-005	Rev. Ind 04
	Page 5 Next 6 Total 16

We reserve all rights in this document and in the information contained therein. Reproduction, use or disclosure to third parties without express authority is strictly forbidden. © Copyright 2003 ABB

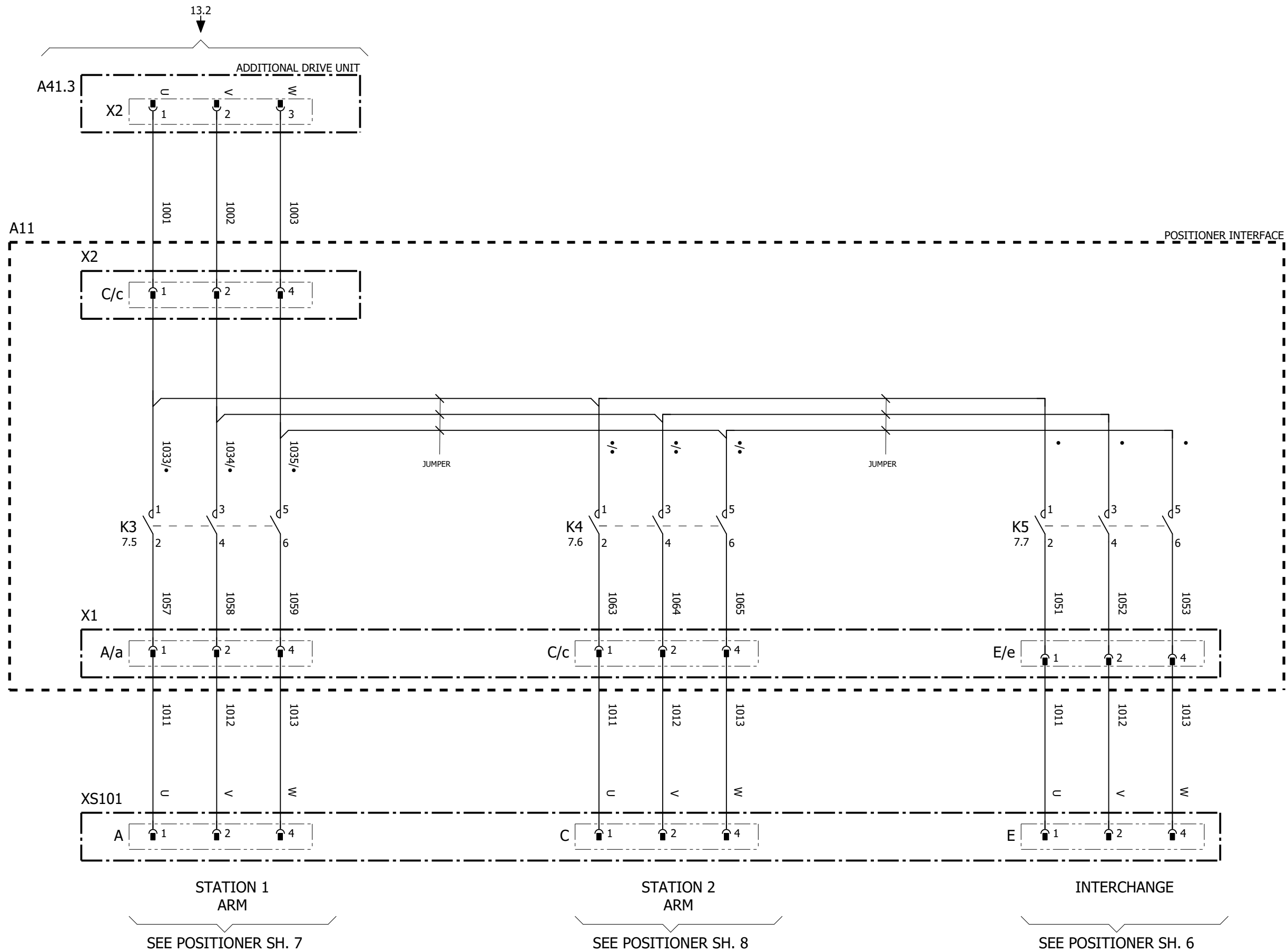

CONNECTED WITH AWG12 BK,
IF NO OTHER NOTATION

Latest revision:
ECO 131728, WI 499329
Page 7/1: A43.X11 was A43.X12.
Page 9.b/2-5: Varistor "X11 to X15" adjusted & JMP (5x) added.
Prepared by, date: EM, 2024-02-13 Approved by, date: SH, 2024-02-22



SERVICE DIAGRAM POS IF B/D.D2009
MOTORS STN 1, STN 2 AND INTERCHANGE

Status: **APPROVED**
Document no. **3HAC035754-005**

Plant: =
Location: +
Sublocation: +
Rev. Ind **04** Page 6
Next 7
Total 16

SEE EL.DWGS FOR THE IRC5 CONTROLLER

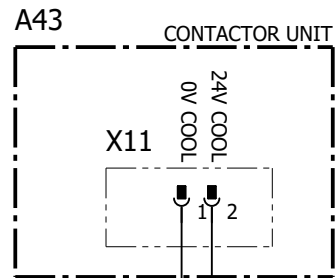

A11

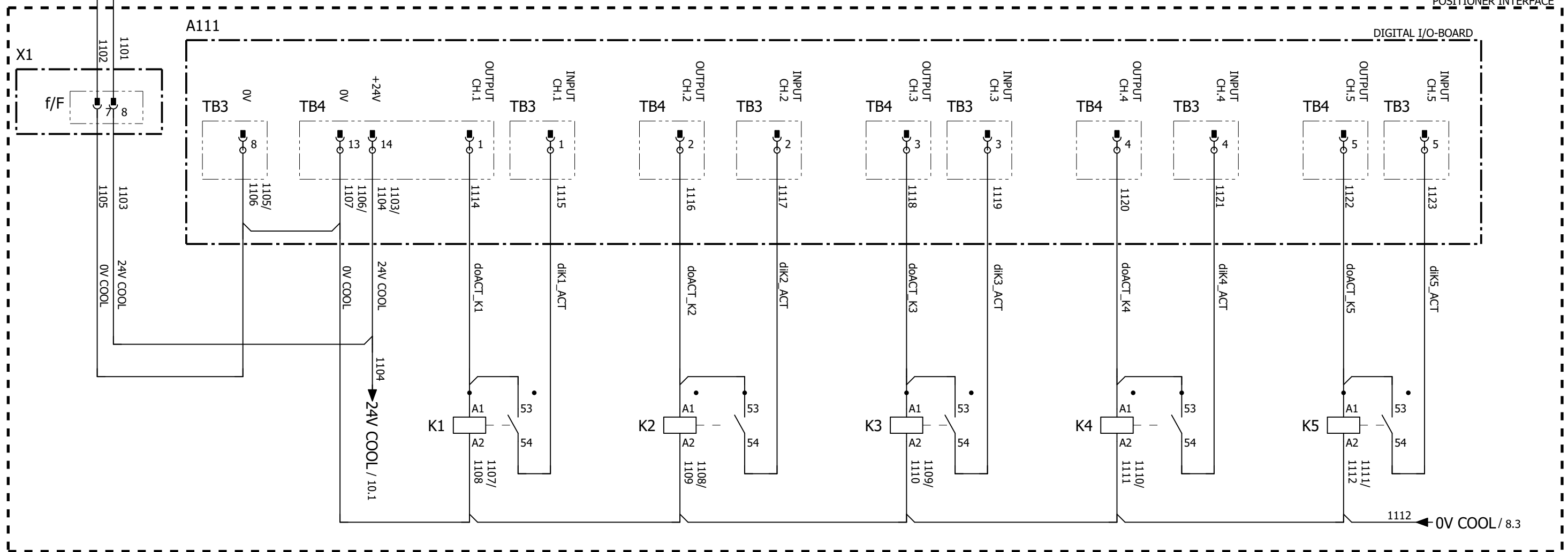

STATION 1
PLATE

STATION 2
PLATE

STATION 1
ARM

STATION 2
ARM

INTERCHANGE

- 1 ⤴ 2 5.3
- 3 ⤴ 4 5.4
- 5 ⤴ 6 5.4
- 13 ⤴ 14 9.a.2
- 13 ⤴ 14 9.b.2
- 53 ⤴ 54 7.3
- 62 ⤴ 61 10.5
- 72 ⤴ 71 10.5

- 1 ⤴ 2 5.5
- 3 ⤴ 4 5.6
- 5 ⤴ 6 5.6
- 13 ⤴ 14 9.a.3
- 13 ⤴ 14 9.b.3
- 53 ⤴ 54 7.4
- 62 ⤴ 61 10.5
- 72 ⤴ 71 10.6

- 1 ⤴ 2 6.2
- 3 ⤴ 4 6.2
- 5 ⤴ 6 6.2
- 13 ⤴ 14 9.a.4
- 13 ⤴ 14 9.b.4
- 53 ⤴ 54 7.5
- 62 ⤴ 61 10.6
- 72 ⤴ 71 10.6

- 1 ⤴ 2 6.4
- 3 ⤴ 4 6.4
- 5 ⤴ 6 6.5
- 13 ⤴ 14 9.a.4
- 13 ⤴ 14 9.b.4
- 53 ⤴ 54 7.6
- 62 ⤴ 61 10.7
- 72 ⤴ 71 10.7

- 1 ⤴ 2 6.6
- 3 ⤴ 4 6.7
- 5 ⤴ 6 6.7
- 13 ⤴ 14 9.a.5
- 13 ⤴ 14 9.b.5
- 53 ⤴ 54 7.8
- 62 ⤴ 61 10.8
- 72 ⤴ 71 10.8

CONNECTED WITH AWG18 BU, IF NO OTHER NOTATION

Latest revision:
 ECO 131728, WI 499329
 Page 7/1: A43.X11 was A43.X12.
 Page 9.b/2-5: Varistor "X11 to X15" adjusted & JMP (5x) added.
 Prepared by, date: EM, 2024-02-13 Approved by, date: SH, 2024-02-22



Lab/Office:
RMRO SE/RDP

SERVICE DIAGRAM POS IF B/D.D2009
MOTORS CONTACTORS

Status:
APPROVED

Plant: =
Location: +
Sublocation: +

Document no.
3HAC035754-005

Rev. Ind Page 7
04 Next 8
Total 16

we reserve all rights in this document and in the information contained therein. Reproduction, use or disclosure to third parties without express authority is strictly forbidden. © Copyright 2003 ABB

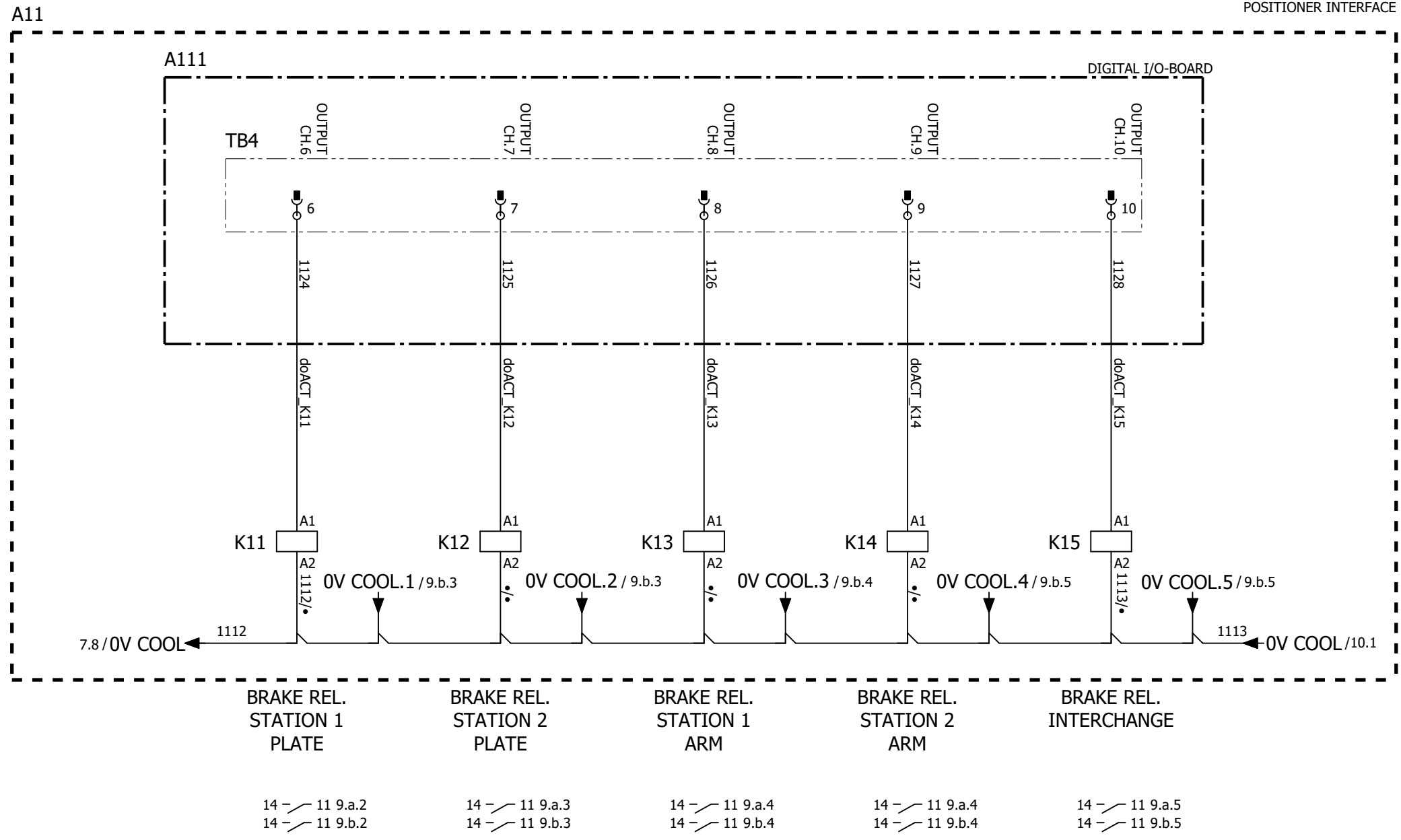

CONNECTED WITH AWG18 BU,
IF NO OTHER NOTATION

Latest revision:
ECO 131728, WI 499329
Page 7/1: A43.X11 was A43.X12.
Page 9.b/2-5: Varistor "X11 to X15" adjusted & JMP (5x) added.
Prepared by, date: EM, 2024-02-13 | Approved by, date: SH, 2024-02-22



Lab/Office:
RMRO SE/RDP

**SERVICE DIAGRAM POS IF B/D.D2009
BRAKE RELEASE**

Status:
APPROVED

Plant: =
Location: +
Sublocation: +

Document no.
3HAC035754-005

Rev. Ind Page 8
04 Next 9.a
Total 16

we reserve all rights in this document and in the information contained therein. reproduction, use or disclosure to third parties without express authority is strictly forbidden. © Copyright 2003 ABB

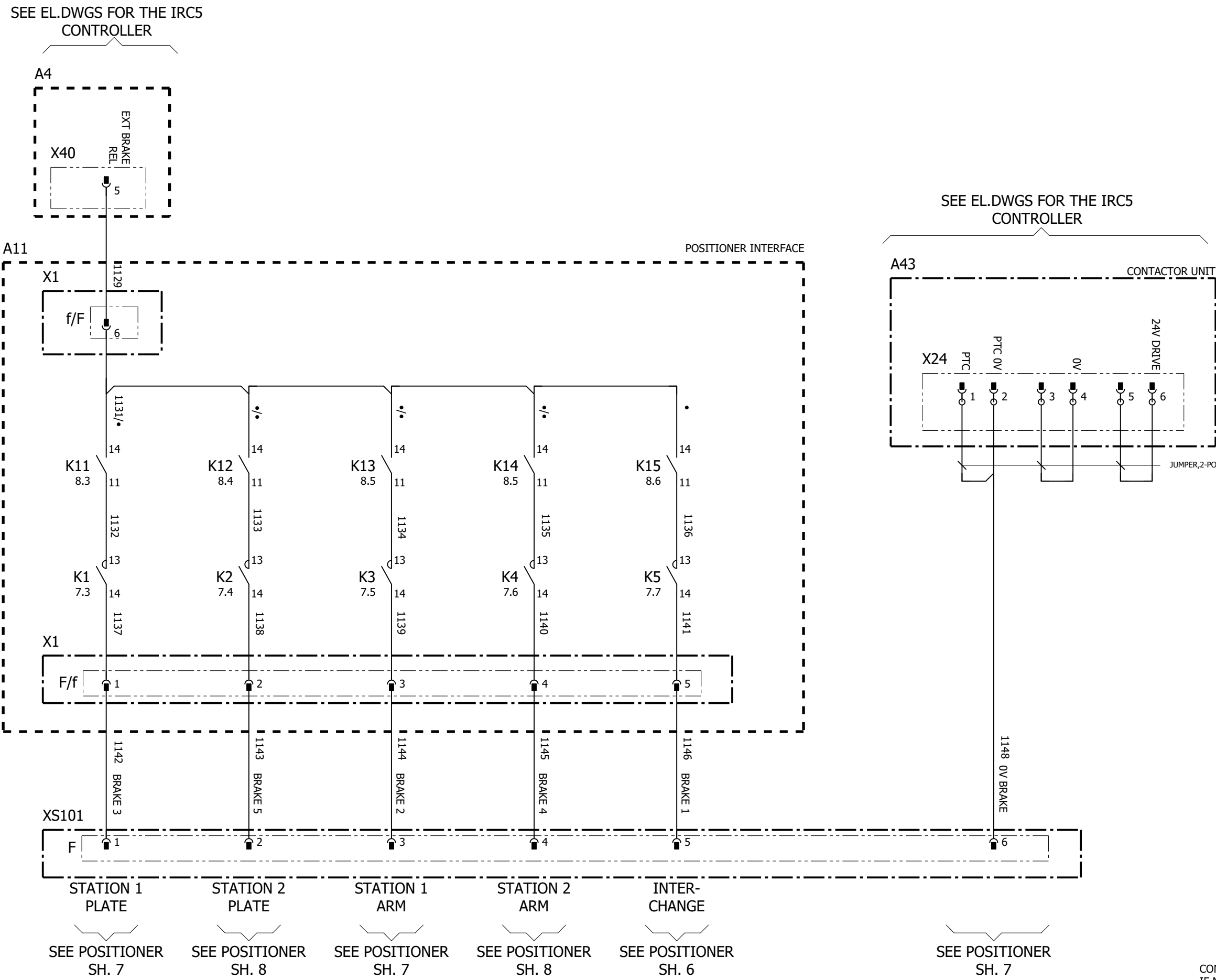

CONNECTED WITH AWG18 BU, IF NO OTHER NOTATION

Latest revision:
 ECO 131728, WI 499329
 Page 7/1: A43.X11 was A43.X12.
 Page 9.b/2-5: Varistor "X11 to X15" adjusted & JMP (5x) added.
 Prepared by, date: EM, 2024-02-13 | Approved by, date: SH, 2024-02-22



Lab/Office:
RMRO SE/RDP

SERVICE DIAGRAM POS IF B/D.D2009
 MOTOR SIGNALS
 BEFORE RELEASE 14.1

Status: APPROVED	Plant: = Location: + Sublocation: +
Document no. 3HAC035754-005	Rev. Ind 04
	Page 9.a Next 9.b Total 16

SEE EL.DWGS FOR THE IRC5 CONTROLLER

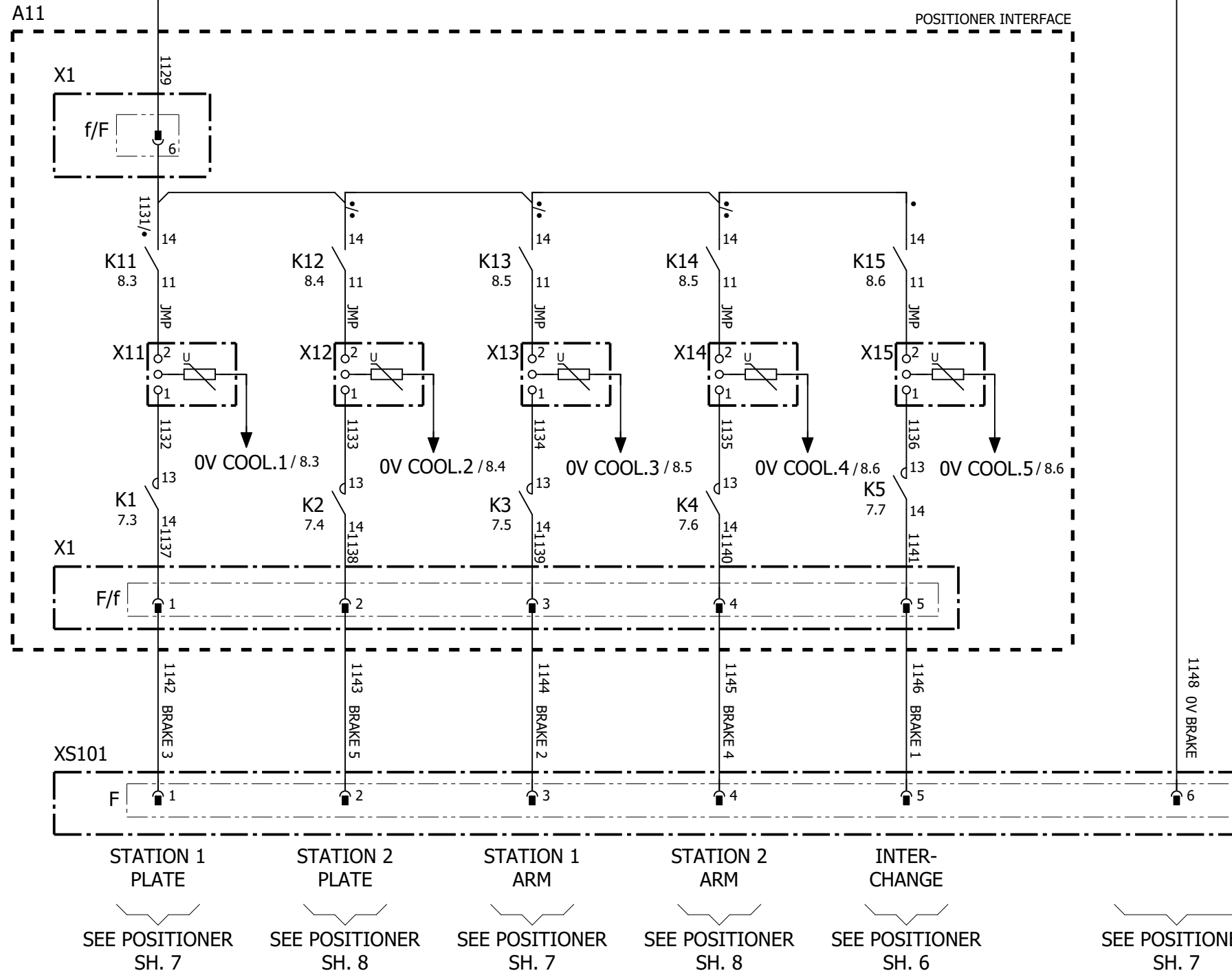
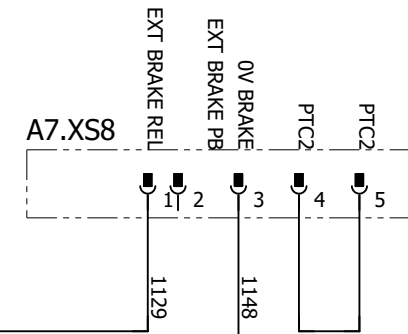

CONNECTED WITH AWG18 BU, IF NO OTHER NOTATION

Latest revision:
 ECO 131728, WI 499329
 Page 7/1: A43.X11 was A43.X12.
 Page 9.b/2-5: Varistor "X11 to X15" adjusted & JMP (5x) added.
 Prepared by, date: EM, 2024-02-13 | Approved by, date: SH, 2024-02-22



Lab/Office:
 RMRO SE/RDP

SERVICE DIAGRAM POS IF B/D.D2009
MOTOR SIGNALS
RELEASE 14.1

Status:
APPROVED

Plant: =
 Location: +
 Sublocation: +

Document no.
3HAC035754-005

Rev. Ind Page 9.b
04 Next 10
 Total 16

We reserve all rights in this document and in the information contained therein. Reproduction, use or disclosure to third parties without express authority is strictly forbidden. © Copyright 2003 ABB

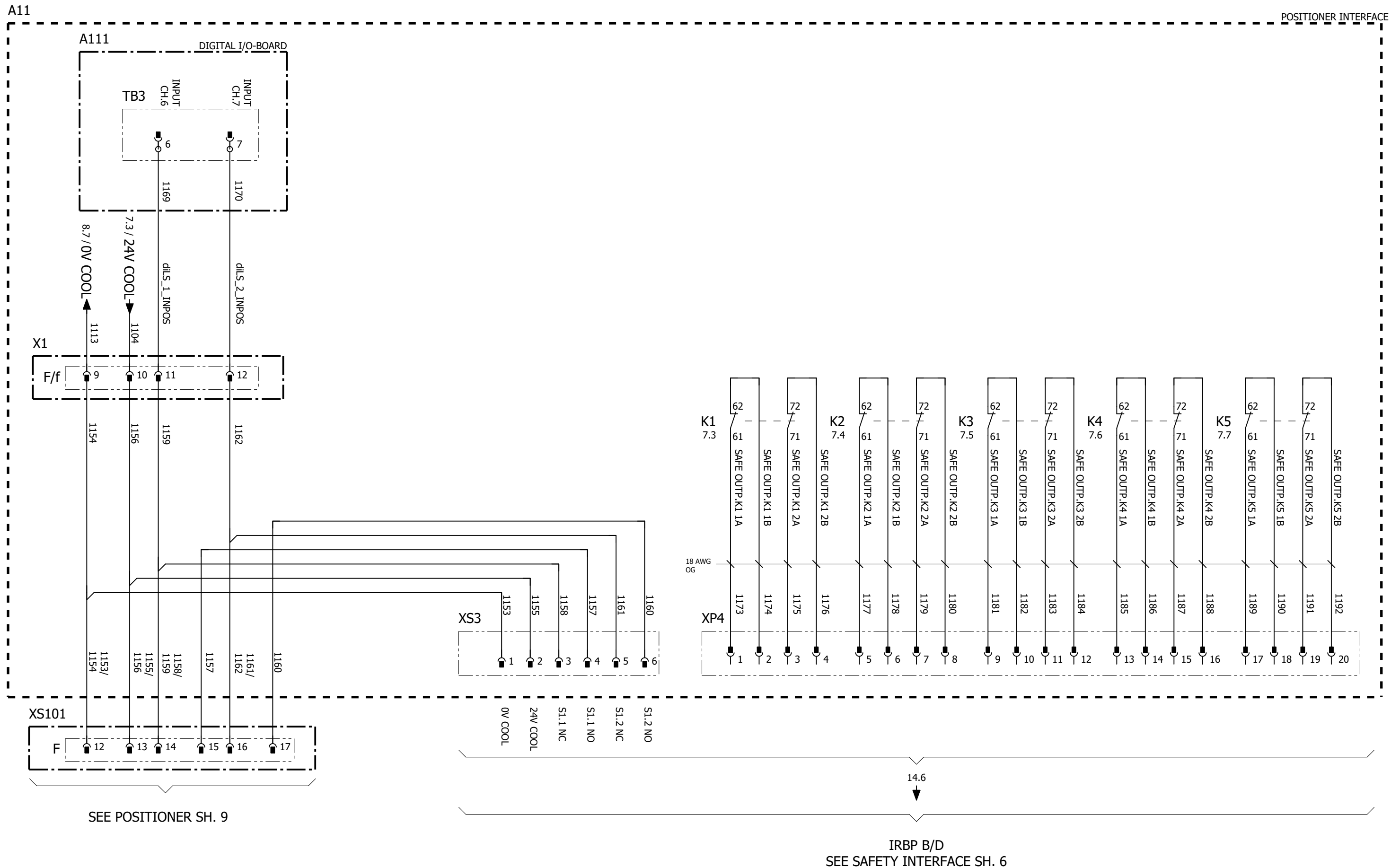

Latest revision:
 ECO 131728, WI 499329
 Page 7/1: A43.X11 was A43.X12.
 Page 9.b/2-5: Varistor "X11 to X15" adjusted & JMP (5x) added.
 Prepared by, date: EM, 2024-02-13 Approved by, date: SH, 2024-02-22



Lab/Office:
RMRO SE/RDP

SERVICE DIAGRAM POS IF B/D.D2009
SAFETY SIGNALS

Status:
APPROVED

Plant: =
 Location: +
 Sublocation: +

Document no. **3HAC035754-005** Rev. Ind **04** Page 10
 Next 11
 Total 16

SEE EL.DWGS FOR THE IRC5
CONTROLLER

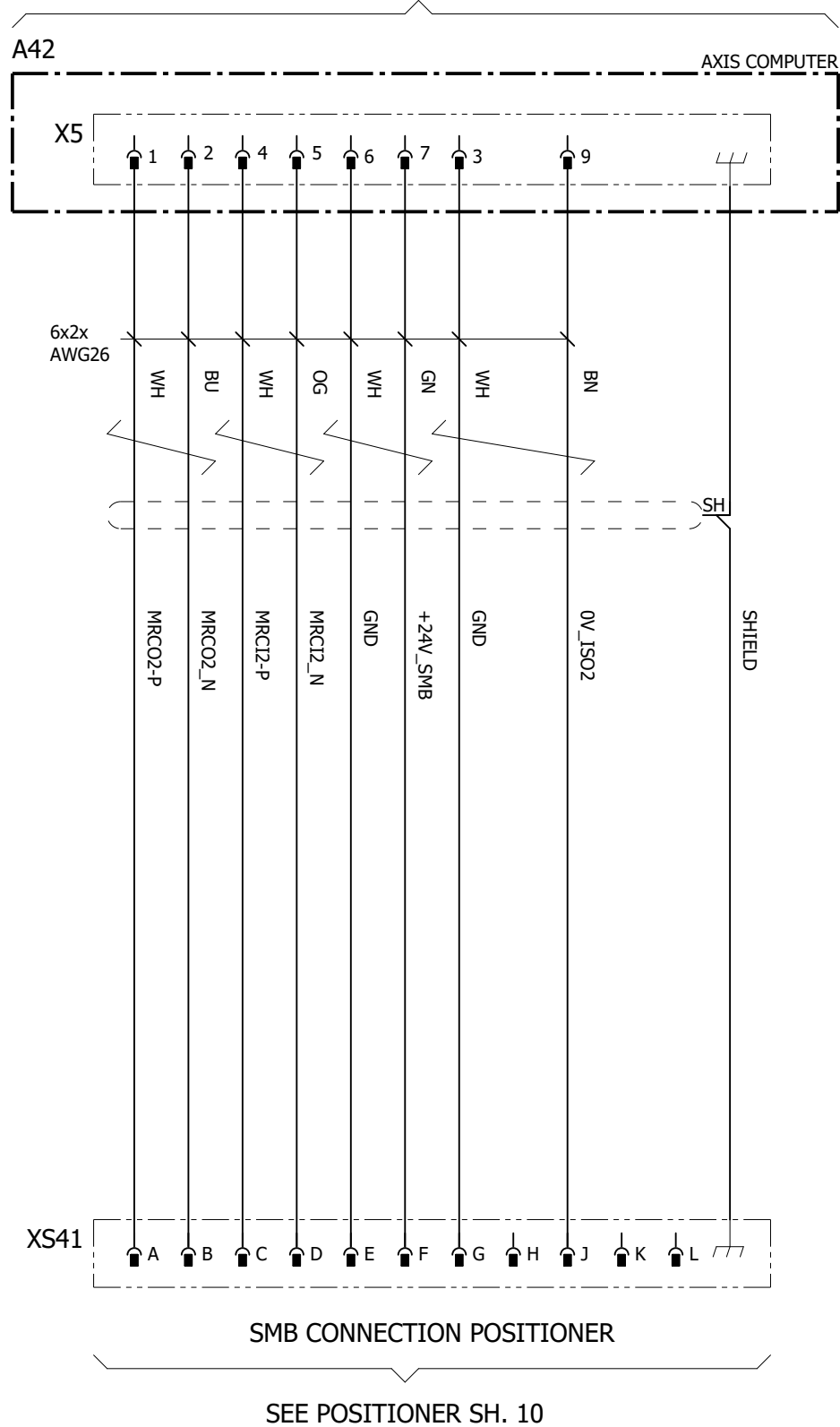

SEE POSITIONER SH. 10

We reserve all rights in this document and in the information contained therein. Reproduction, use or disclosure to third parties without express authority is strictly forbidden. © Copyright 2003 ABB

Latest revision:
ECO 131728, WI 499329
Page 7/1: A43.X11 was A43.X12.
Page 9.b/2-5: Varistor "X11 to X15" adjusted & JMP (5x) added.
Prepared by, date: EM, 2024-02-13 | Approved by, date: SH, 2024-02-22



Lab/Office:
RMRO SE/RDP

SERVICE DIAGRAM POS IF B/D.D2009
MEASUREMENT SYSTEM

Status: APPROVED	Plant: = Location: + Sublocation: +
Document no. 3HAC035754-005	Rev. Ind 04
	Page 11 Next 12 Total 16

SEE EL.DWGS FOR THE IRC5 CONTROLLER

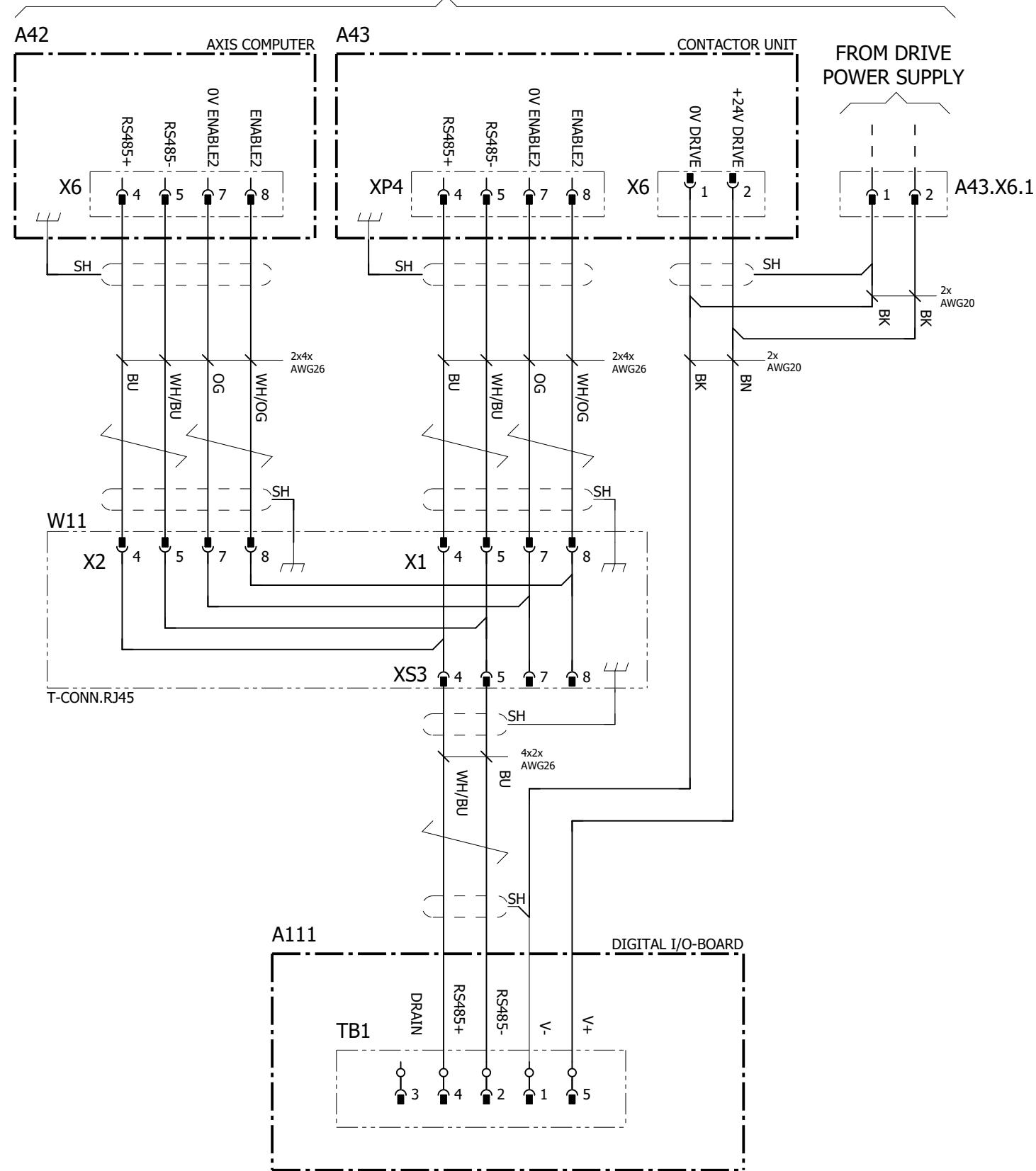

We reserve all rights in this document and in the information contained therein. Reproduction, use or disclosure to third parties without express authority is strictly forbidden. © Copyright 2003 ABB

Latest revision:
 ECO 131728, WI 499329
 Page 7/1: A43.X11 was A43.X12.
 Page 9.b/2-5: Varistor "X11 to X15" adjusted & JMP (5x) added.
 Prepared by, date: EM, 2024-02-13 | Approved by, date: SH, 2024-02-22



Lab/Office:
RMRO SE/RDP

**SERVICE DIAGRAM POS IF B/D.D2009
 BUS CONNECTIONS**

Status: APPROVED	Plant: = Location: + Sublocation: +
Document no. 3HAC035754-005	Rev. Ind 04
	Page 12 Next 13 Total 16

SEE EL.DWGS FOR THE IRC5 CONTROLLER

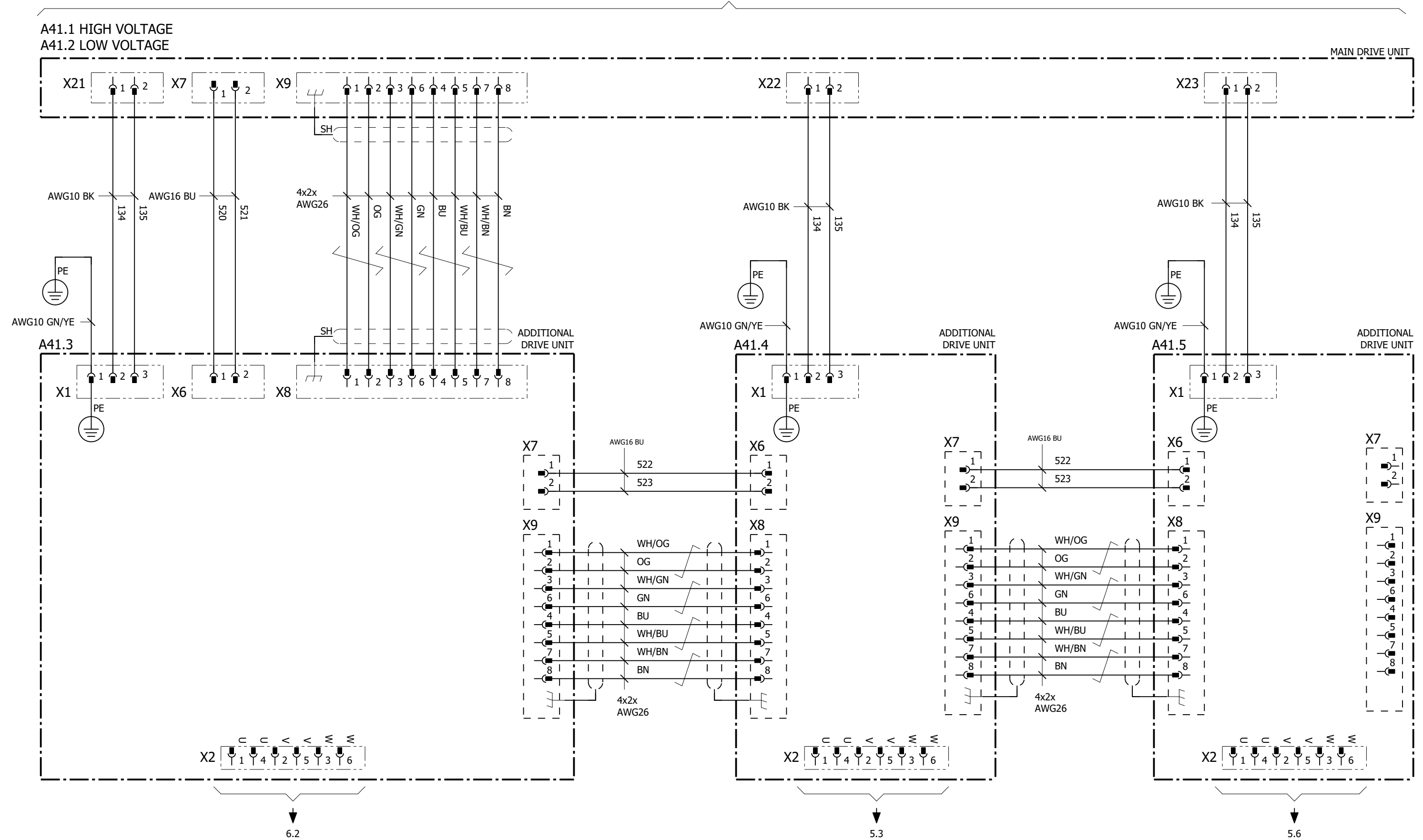

We reserve all rights in this document and all the information contained therein. Reproduction, use or disclosure to third parties without express authority is strictly forbidden. © Copyright 2003 ABB

Latest revision:
 ECO 131728, WI 499329
 Page 7/1: A43.X11 was A43.X12.
 Page 9.b/2-5: Varistor "X11 to X15" adjusted & JMP (5x) added.
 Prepared by, date: EM, 2024-02-13 Approved by, date: SH, 2024-02-22



Lab/Office:
RMRO SE/RDP

**SERVICE DIAGRAM POS IF B/D.D2009
DRIVE SYSTEM**

Status:
APPROVED

Plant: =
 Location: +
 Sublocation: +

Document no.
3HAC035754-005

Rev. Ind **04** Page 13
 Next 14
 Total 16

A11

POSITIONER INTERFACE

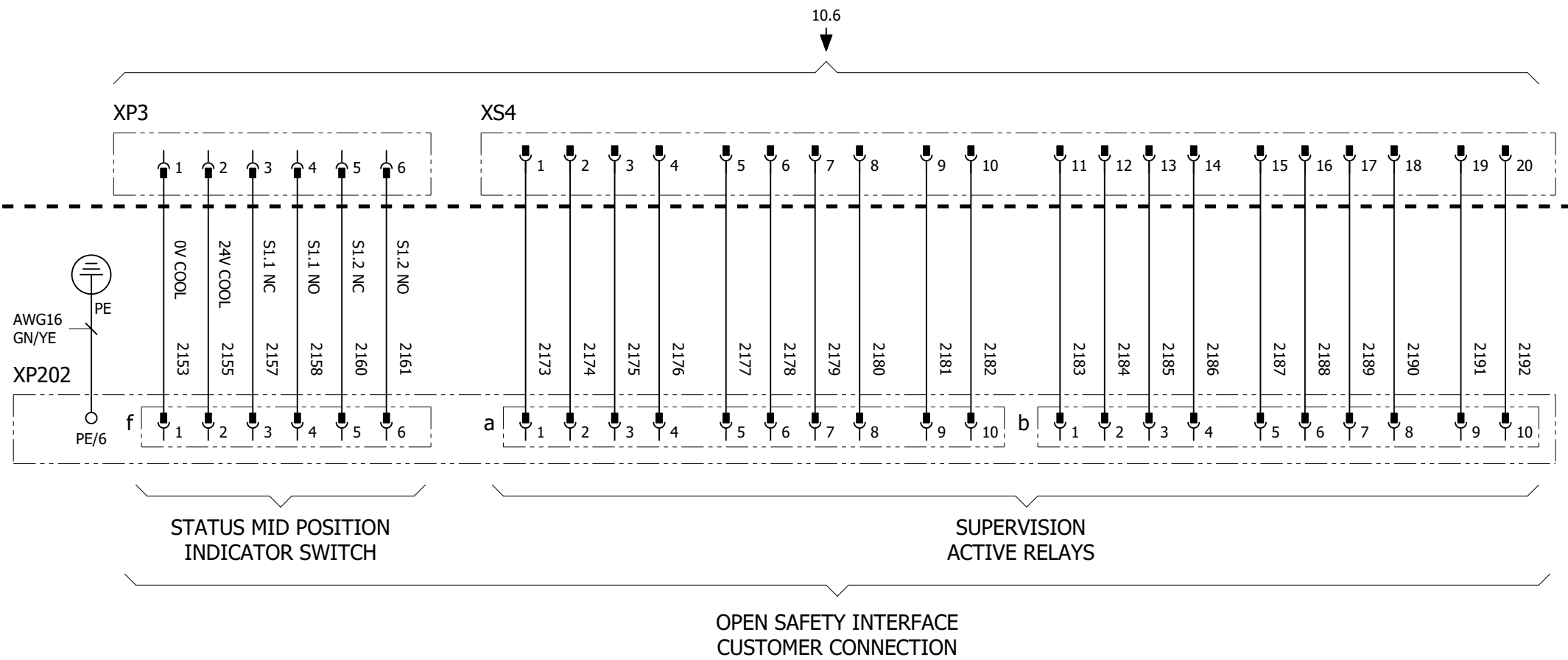

CONNECTED WITH AWG18 OG,
IF NO OTHER NOTATION

Latest revision:
ECO 131728, WI 499329
Page 7/1: A43.X11 was A43.X12.
Page 9.b/2-5: Varistor "X11 to X15" adjusted & JMP (5x) added.
Prepared by, date: EM, 2024-02-13 | Approved by, date: SH, 2024-02-22



Lab/Office:
RMRO SE/RDP

SERVICE DIAGRAM POS IF B/D.D2009
OPTION SUPERVISION ACTIVE RELAYS

Status:
APPROVED

Plant: =
Location: +
Sublocation: +

Document no.
3HAC035754-005

Rev. Ind **04** | Page 14
Next
Total 16

We reserve all rights in this document and in the information contained therein. Reproduction, use or disclosure to third parties without express authority is strictly forbidden. © Copyright 2003 ABB